

Block Manufactured Using C50 Strength Concrete

Weight of Block : 2000kg Approx.

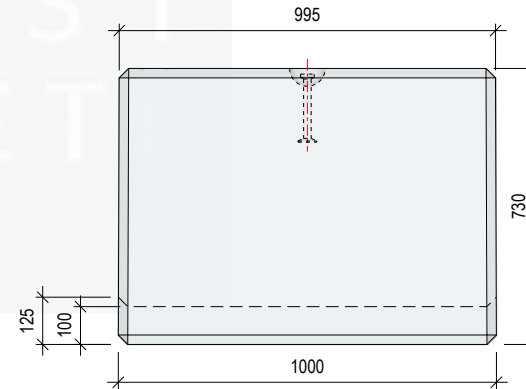
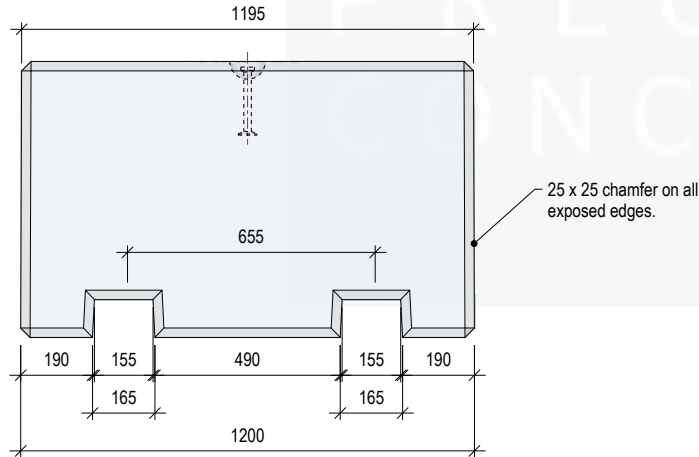
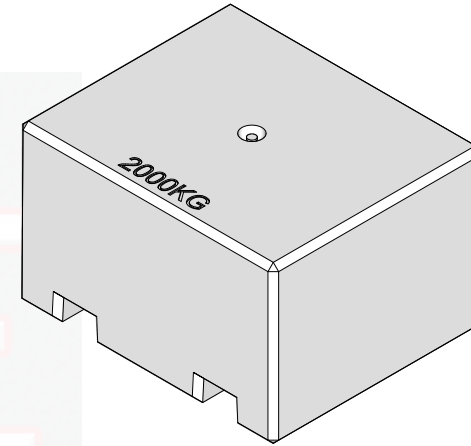
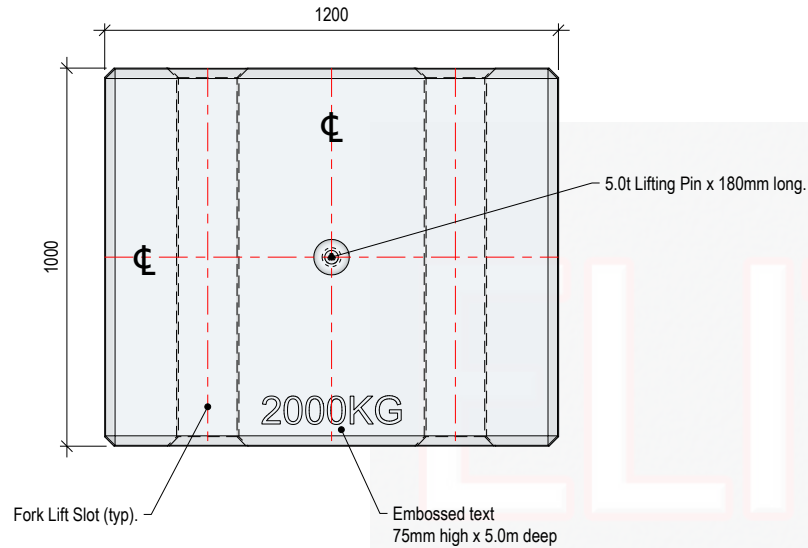

REV	DATE	REASON FOR ISSUE	DRN	APP
0	15-10-25	First Issue.	CTC	-

TITLE

KS2000 Ballast Block (Full Chamfer)
 1200mm x 1000mm x 730mm
 Elite Product Code : **BallastKS2000**

ELITE PRECAST CONCRETE LTD
 UNIT O, HALESFIELD 9
 TELFORD TF7 4QW
 Tel : 01952 588885
 www.eliteprecast.co.uk
 email : sales@eliteprecast.co.uk



DRN CTC

CHKD -

DATE 15-10-25

SIZE A4

SCALE 1:20

DRG EPC-KS2000

REV 0