

Retained Material:-  
 Sand  
 AoR = 30 degrees  
 Maximum Density  
 12 kN/m<sup>3</sup> (1200 kgs/m<sup>3</sup>)

**It is up to the client to advise if these parameters are not correct.**

### Design Parameters

(1:25)

**NOTE:-**  
 The bearing pressure beneath the wall is shown below. **It is up to the client to ensure the ground and slab is adequate**, alternatively a foundation may be designed to suit allowable ground bearing pressures if required.

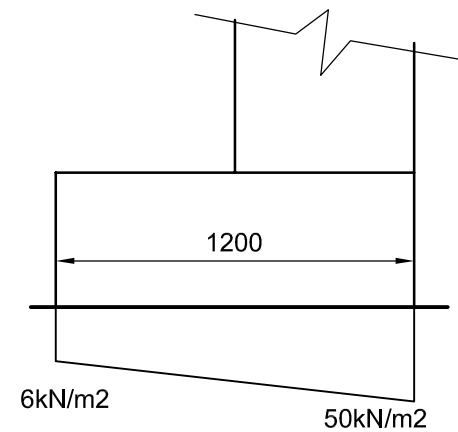

Bearing Pressure  
Directly Beneath Wall

### Bearing Pressures

(1:25)

**NOTES:-**

1. The contractor should take all necessary measurements on site.
2. All dimensions shown on this drawing are approximate and for structural calculation purposes only.
3. Dimensions on this drawing should not be used for fabrication purposes.
4. Do not scale this drawing.
5. This drawing should be read in conjunction with the calculations.

**IMPORTANT NOTE**

The existing slab and ground have not been investigated by CLP structures, the pressures exerted on the ground and slab are shown on this drawing, however **it is up to the client to satisfy himself that the existing ground and slab are adequate to support these loads.**

**IMPORTANT NOTE**

The wall has been designed to retain a specific material with a specific density and angle of repose. It is up to the client to ensure that the material retained on site does not exceed these designed parameters, failure to do so may result in the collapse of the wall.

Rev	Description	By	Date	Chk'd
Purpose of Issue		Rev	Date	Auth



**CLP Structures**  
 STRUCTURAL ENGINEERING CONSULTANTS  
 EMAIL: mail@CLP-Structures.co.uk  
 TEL: 0117 3706357

Client  
**Elite Precast Concrete Ltd.**

Project  
**Elite Duoblock Wall**

Title  
**Wall Design Parameters and Limitations**

Original Scale As noted	Drawn CEL Date Aug 16	Rev - Checked
----------------------------	-----------------------------	---------------

Drawing Number **507-08**