

Plan

Ø74mm dia semi-spherical recess in gravitational centre of block for pin anchor.
(pin anchor is rated to 2.5 tonnes with a safety factor of 3).

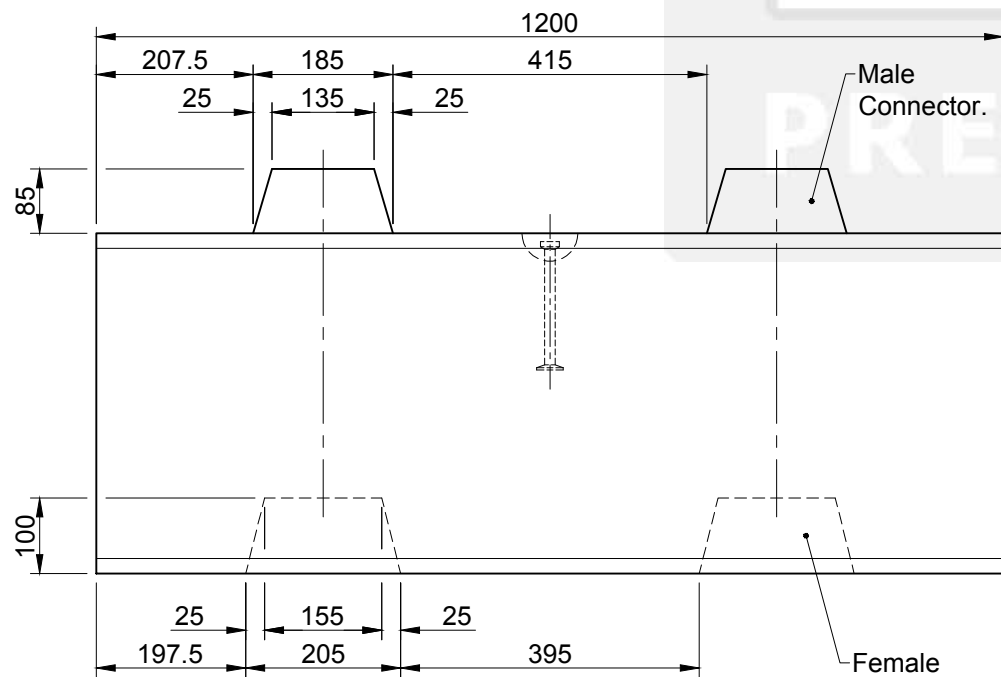

Elevation

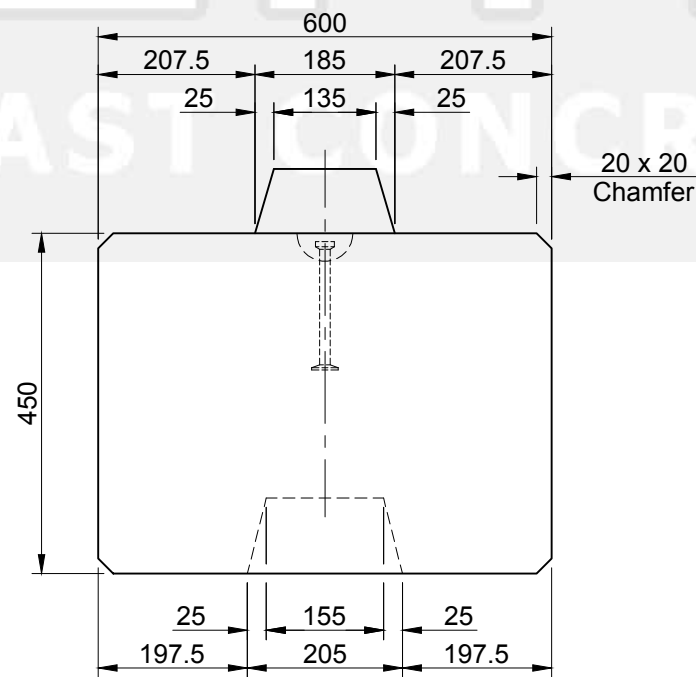

End

1. Handling

- Unit Volume / Weight

Unit Ref	Volume (m ³)	Weight (kg)
BL2	0.321	750

- Weight is based on 2350 kg/m³
- Lifting system is by means of a 170mm long spherical pin anchor rated at 2.5 tonnes with a safety factor of 3.
- Lifting is achieved by use of a 2.5t rated pin anchor ring clutch or combination ring clutch only and should comply with the Lifting Operation & Lifting Equipment Regulations 1998 (LOLER).

2. Concrete

- Characteristic 28 day cube strength = 50 N/mm² min.
- Concrete is Class A1 Fire Resistant in accordance with clause 4.3.4.4 of EN 13369.

3. Manufacture

- Manufactured to : BS EN 13369 : 2013
- Tolerances to : BS EN 13670 : 2009

4. Physical & Chemical Properties

- Appearance : Grey in Colour
- Other Chemical Properties : Not Applicable

5. Design

- Design Life : >100 years

6. Manufacture Tolerances

- Length ± 5mm
- Width ± 5mm
- Height ± 5mm

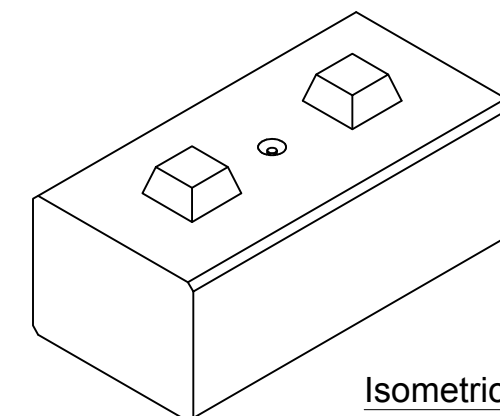

Isometric View

REV	DATE	REASON FOR ISSUE	DRN	APP	REV	DATE	REASON FOR ISSUE	DRN	APP	TITLE	SIZE	SCALE	DRG	REV
										Duo™ Interlocking Concrete Block BL2 1200 x 600 x 450mm (M / F Interlocks) Elite Product Code : BL2	A3	1:10	EPC-DUO-002	A
					A	03.01.18	Drawing revised & updated.	CTC	RMD					
					O	23.06.16	For Information.	CTC	RMD					
										DATE 23-06-16				

